

INT250[®] Oil differential pressure switch

INT250[®]

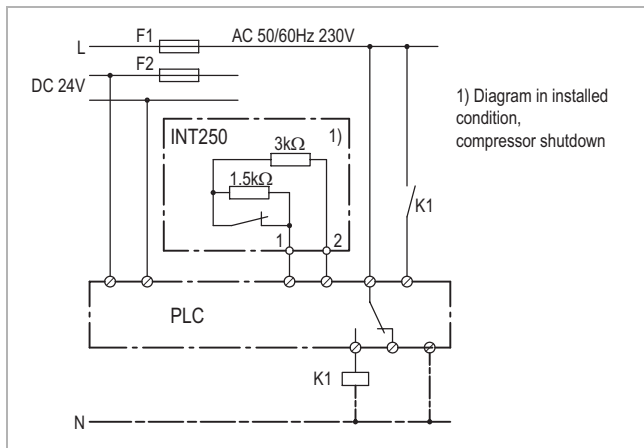

INT250



Wiring diagram

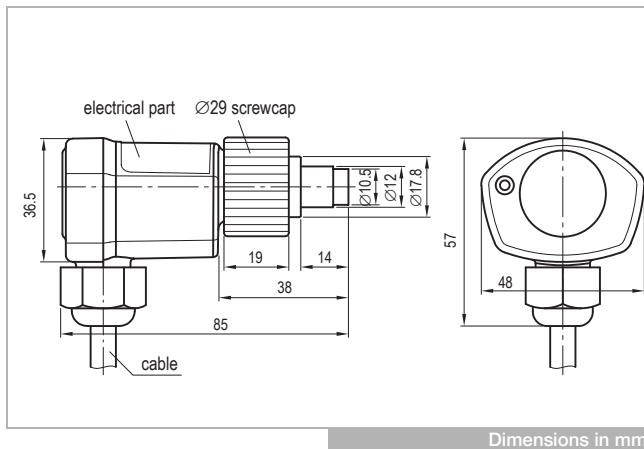

Dimensions in mm

Application

The INT250 serves to monitor the oil differential pressure of oil pumps in refrigeration compressors. For this a screw-in part that is mounted directly in the pump housing is evaluated for differential pressure measurement. The screw-in part is thereby connected by internal channels with the suction and high pressure side of the pump. Supplementary pipe connections are not needed. The INT250 is fastened by a coupling ring in the screw-in part and can be removed without opening the oil/refrigeration circuit.

Functional description

The differential pressure sensor, which is integrated into the screw-in part, monitors the oil differential pressure for exceeding or dropping below a fixed set threshold and signals this to the switching unit as a digital signal. This signal is converted immediately into a switch position of the output contact (reed contact) and can be evaluated as a switch signal at terminal 1/2 or 1/3. Since the output contact reacts to a differential pressure change without delay, the downstream evaluation circuitry (e.g. SPS) needs to contain a delay (debouncing). The time delays that are recommended by the compressor manufacturer for the exceeding or dropping below the fixed set differential pressure limits need to be integrated into the downstream evaluation circuitry.

Installation instructions

Mounting: Insert the INT250 in the screw-in unit and screw tight by hand with the coupling ring (torque about 10Nm. Make sure that the cable outlet points down. The electrical connection needs to be carried out according to the wiring diagram.



The mounting, maintenance and operation are to be carried out by an electrician. The valid European and national standards for connecting electrical equipment and refrigeration plants have to be observed. Connected sensors and connection lines that extend from the terminal box have to feature at least a basic insulation. It should not be subjected to strong magnetic fields.

Technical specifications

Permitted ambient temperature	-30...+70°C
Switching voltage	Max. AC 50/60Hz 12V Max. DC 24V
Switching current	Max. 10mA
Switching capacity	0.2VA
Mechanical service life	Approx. 10 mio. switching cycles
Protection class acc. to EN 60529	IP54
Connecting cable	2xAWG18 (0.75mm ²), L=1m Ferrules
Max. lead length (supplied by customer)	L < 30m
Housing material	PA glass-fibre-reinforced
Weight	Approx. 80g
Mounting	Union nut
Check base	EN 61000-6-2 EN 61000-6-3 EN 61010-1 Overvoltage category II Pollution level 2
Approvals	UL File No. E222056

Exclusively applicable screw-in units: Technical data sheet 700.00364

Order data

INT250 Oil differential pressure switch	02 S 667
INT250 Ex Oil differential pressure switch	02 S 667 S31

Technical changes reserved